

# CC-Link **IE** **F**ield

Ethernet-based Open Network

**CC-Link IE Field Network  
Cable Installation Manual**



This manual describes the items to consider installing a network using CC-Link IE field network compatible products in advance, the items to be checked at the construction site, and precautionary items to be followed at installation. We hope that you find this manual useful in achieving smooth CC-Link IE field network installation.

## CONTENTS

Chapter 1	NETWORK CONFIGURATION PROCEDURE .....	3
Chapter 2	NETWORK SPECIFICATIONS.....	4
2.1	Network Construction Overview.....	4
2.2	Network Configuration.....	5
2.3	Network Specifications .....	5
2.4	Topology .....	6
2.5	Effects from Temperature .....	7
Chapter 3	SELECTING CONNECTION DEVICES .....	8
3.1	Cables .....	8
3.2	Connectors (Plugs, Jacks) .....	8
3.3	Relay Connectors.....	8
3.4	Layer 2 Switch.....	9
Chapter 4	CHECKING THE WIRING .....	10
4.1	Wiring Length .....	10
4.2	Number of Connectors .....	12
4.3	Connecting Connectors (Plugs/Jacks) and Cables.....	12
4.4	Transmission Characteristics .....	13
Chapter 5	INSTALLATION AND WIRING .....	17
5.1	Points to keep in mind to set up cable wiring.....	17
5.2	Grounding Method.....	18

## Chapter 1 NETWORK CONFIGURATION PROCEDURE

Procedure for cable wiring of CC-Link IE field network is as following.

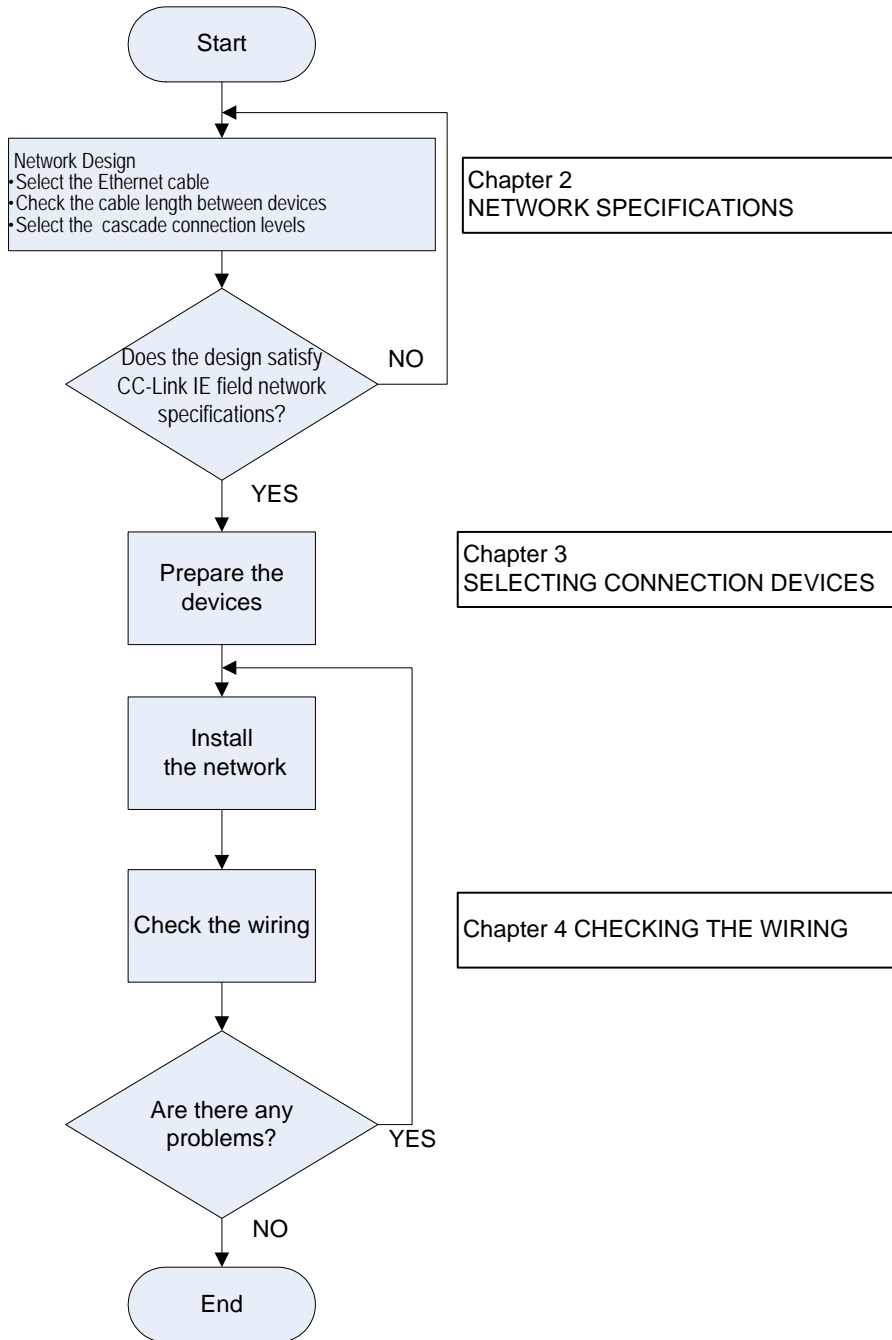

Fig. 1 Installation Procedure

## Chapter 2 NETWORK SPECIFICATIONS

### 2.1 Network Construction Overview

#### CC-Link IE field network components

**Station:** A device that is connected via the CC-Link IE field network to which any of station numbers 0 and 253. can be assigned:

#### **Master station**

A node that has control information (parameters) and manages cyclic transmission.

#### **Local station**

A node capable of performing n:n bit data and word data cyclic transmission and transient transmission with the master station and other local stations, and transient transmission with slave stations, excluding remote I/O stations. Has server functions and client functions during transient transmission.

#### **Intelligent device station**

A node capable of performing 1:n bit data and word data cyclic transmission and transient transmission with the master station, and transient transmission with slave stations, excluding remote I/O stations. Has server functions and client functions during transient transmission.

#### **Remote device station**

A node capable of performing 1:n bit data and word data cyclic transmission and transient transmission with the master station, and transient transmission with slave stations, excluding remote I/O stations. Has server functions during transient transmission.

#### **Remote I/O station**

A node capable of performing 1:n bit data cyclic transmission with the master station.

#### **Slave station**

A general term for a node (local station, remote I/O station, remote device station, intelligent device station) other than the master station.

**Cables:** ANSI/TIA/EIA-568-B (Category 5e) compliant cables.

**Connectors:** ANSI/TIA/EIA-568-B (Category 5e) compliant RJ45 connectors.

**Layer 2 switch:** A relay device having multiple Ethernet ports that transfers frames using a data link layer process. Sometimes it referred to as a switching HUB. Star topology is available.. Also a line mixed with star topology is available .

## 2.2 Network Configuration

A CC-Link IE field network station is specified by its network number and station number. Each network is identified by a network number. And communication data are relayed between networks by relay stations, in which communication data are relayed between networks.

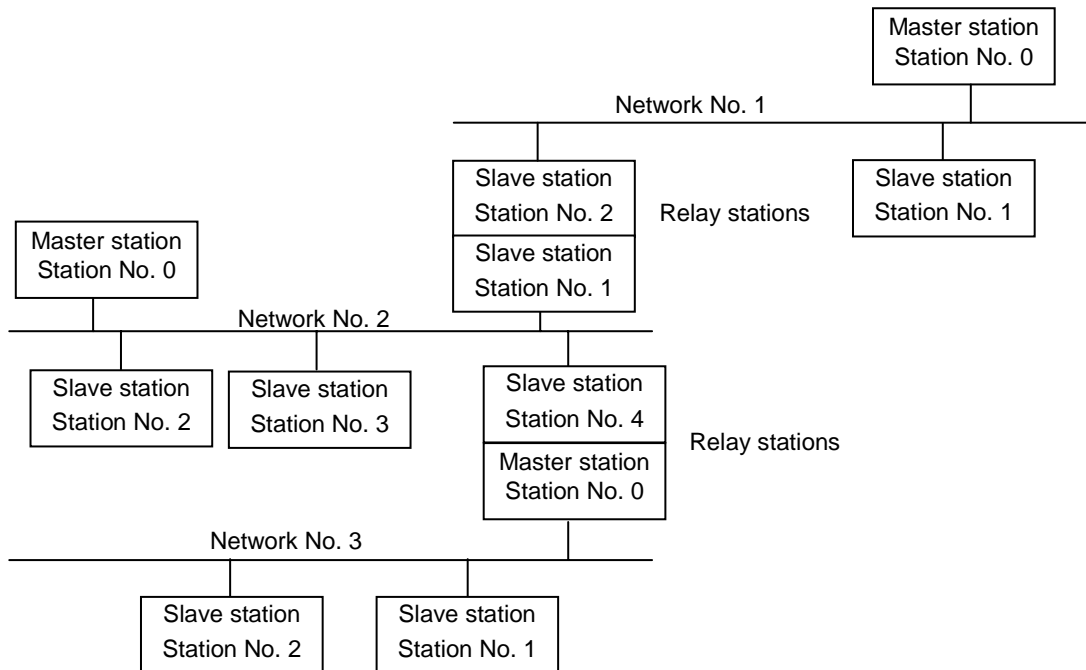

**Fig. 2 Network Configuration**

## 2.3 Network Specifications

The CC-Link IE field network is an Ethernet based network that employs IEEE802.3 (1000Base-T) technology on its physical and data link layers. Table 1 describes the communication specifications related to the cable installation of the CC-Link IE field network.

**Table 1 Communication Specifications**

Item	Specifications	
Communication speed	1Gbps	
Maximum number of networks	239	
Number of connected nodes per network	Master station	1
	Slave station	253
Cable specifications	IEEE802.3 1000Base-T cable ANSI/TIA/EIA-568-B (Category 5e) compliant 4-pair balanced-type shield cable Double-shield type is recommended	
Connector specifications	ANSI/TIA/EIA-568-B (Category 5e) compliant RJ45 connector with shield	
Cable length between devices	Maximum length: 100m [ANSI/TIA/EIA-568-B (Category 5e) compliant]	

## 2.4 Topology

The CC-Link IE field network topology has line, star, or ring topology. There are some layer 2 switches in star topology. Line mixed with star topology is also available.

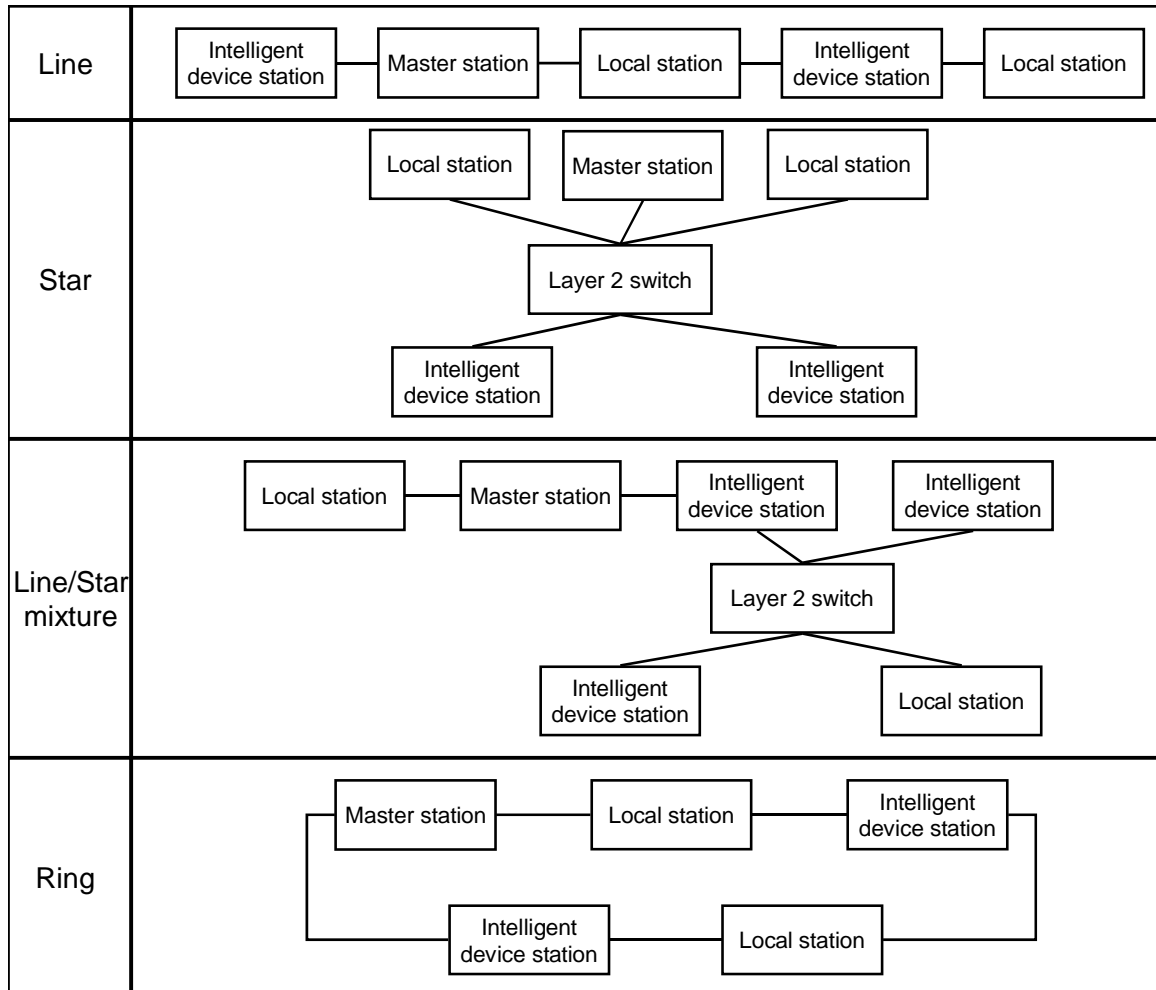

## 2.5 Effects from Temperature

The maximum length between the devices in the CC-Link IE field network differs according to the operating temperature environment (cable installation environment). Determine the cable length between devices by referring to the target values in Table 2.

Specifically, calculate the insertion loss between devices using the insertion loss analysis formula in Section 4.4, and verify that the value is within specified values.

**Table 2 Temperature Environment and Maximum Length Between Devices (Example)**

Cable Ambient Temperature (°C)	Maximum Cable Length L [m]	Maximum Length Between Devices [m] (Channel including patch cord of Figure 3)
20	90.0	100.0
25	89.5	99.5
30	88.5	98.5
35	87.7	97.7
40	87.0	97.0
45	86.5	96.5
50	85.5	95.5
55	84.7	94.7
60	83.0	93.0

(Standard used as reference: "ANSI/TIA/EIA-568-B.2-1 Annex G")

Conditions: In Table 2, a channel that includes a 10m patch cord or device cord (under an environment of 20°C) is assumed, as in Figure 3.

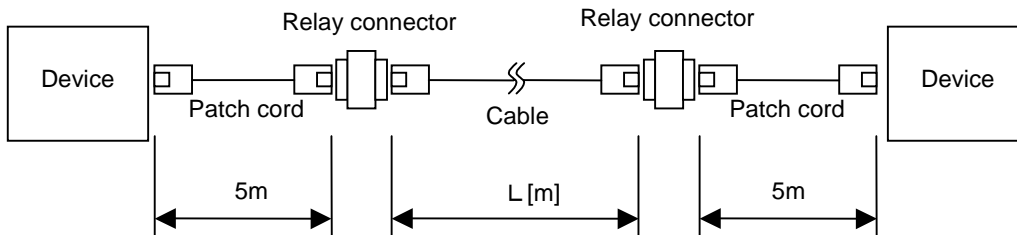

**Fig. 3 Temperature Environment and Channel Block Diagram**



## Chapter 3 SELECTING CONNECTION DEVICES

### 3.1 Cables

In the CC-Link IE field network, use ANSI/TIA/EIA compliant Ethernet cables (Category 5e or higher). Operating in a harsh environment(not OA environment), we recommend using CLPA recommended cables that have passed CLPA'S TEST( noise tests, CC-Link IE field network system tests, and so on).

**Table 3 CC-Link IE Field Network Recommended Cable Specifications**

Item	Specifications
Cable type	4-pair balanced type shield cable Double-shield type
Compliant standards	ANSI/TIA/EIA-568B (Category 5e)
No. of core wires	8 core wires (4 twisted pairs)
Double shield	Aluminum tape
	Annealed copper braided wire

Cross-section example

Core Wire Identification (Color of Insulating Material)	
Core Wire 1	Core Wire 2
Blue	White/Blue
Orange	White/Orange
Green	White/Green
Brown	White/Brown

**Note: When arranging wires across a long distance, use single conductor cables of 24AWG or higher. For details, refer to Chapter 4.**

### 3.2 Connectors (Plugs, Jacks)

Use ANSI/TIA/EIA-568-B (Category 5e) compliant RJ45 connectors with shields.

### 3.3 Relay Connectors

Use relay connectors compliant with ANSI/TIA/EIA-568-B (Category 5e) RJ45 jack specifications. Also, use relay connectors with shields.

## 3.4 Layer 2 Switch

In the CC-Link IE field network, use a layer 2 switch that satisfies the conditions below. Use of a repeater hub is not permitted.

- [1] IEEE802.3 1000Base-T compliant
- [2] Auto MDI/MDI-X function mounted
- [3] Auto negotiation function mounted

### 3.4.1 Estimating the number of layer 2 switches

Given the following:

No. of layer 2 switches = A

Latency (μsec) of layer 2 switch i = Bi

No. of slave stations = C

Latency (μsec) of slave station j = Dj (target: 1.5μsec)

Value (μsec) of token monitoring time (NetWatchTimer) in master station = E (target: 1,500μsec)

Install layer 2 switches the quantity of witch is less than or equal to that satisfies in the formula below.

(Latency of total number of layer 2 switches + Latency of total number of slave stations + Transmission path delay) x 2 + Token hold time

$$= \left( \sum_{i=1}^A B_i + \sum_{j=1}^C D_j + 0.555 \mu \text{ sec} \times (A + C) \right) \times 2 + 300 \mu \text{ sec} (\text{maximum value}) \leq E$$

[Calculation Example]

For example, given the following:

No. of layer 2 switches = A = 20

Latency of layer 2 switch i = Bi = 8.0μsec

No. of slave stations = 120 stations

Latency of slave station j = Dj = 1.5μsec

Value (μsec) of token monitoring time (NetWatchTimer) in master station = E = 1,500μsec

Then:

$$= \left( \sum_{i=1}^{20} 8.0 \mu \text{ sec} + \sum_{j=1}^{120} 1.5 \mu \text{ sec} + 0.555 \mu \text{ sec} \times (20 + 120) \right) \times 2 + 300 \mu \text{ sec}$$

$$= 1135.4 \mu \text{ sec} \leq 1,500 \mu \text{ sec} (= E)$$

Therefore, the number of installable layer 2 switches is 20.

#### Caution

The latency of the layer 2 switch varies according to the system configuration and presence of faulty stations as well as each layer 2 switch type. Using the Layer 2 switch in a actual system in advance, we recommend testing the system in an environment close to that of the actual system.

## Chapter 4 CHECKING THE WIRING

The wiring between CC-Link IE field network devices (or between a CC-Link IE field network device and a layer 2 switch when a layer 2 switch is used) requires compliance with the standard ANSI/TIA/EIA-568-B Category 5e. At installation, be sure to check the following:

- [1] Wiring length
- [2] Number of connectors
- [3] Connector (plug/jack) and cable connection
- [4] Transmission characteristics

### 4.1 Wiring Length

The specification for the physical wiring length between devices in a CC-Link IE field network is 100m, maximum. (The term “device” refers to a CC-Link IE field network device, layer 2 switch, and so on. Passive components such as connectors that connect cables do not fall under the category of device, and are regarded as a part of the wiring.)

The ANSI/TIA/EIA-568-B standard which defines wiring specifications specifies channel transmission characteristics other than cable unit and connector unit transmission characteristics. The wiring between two devices is called channel that includes cables and connectors.

In the example in Figure 4, there are five channels that connect devices. The required wiring length of each channel is 100m or less. And each channel must satisfy specified transmission characteristics.

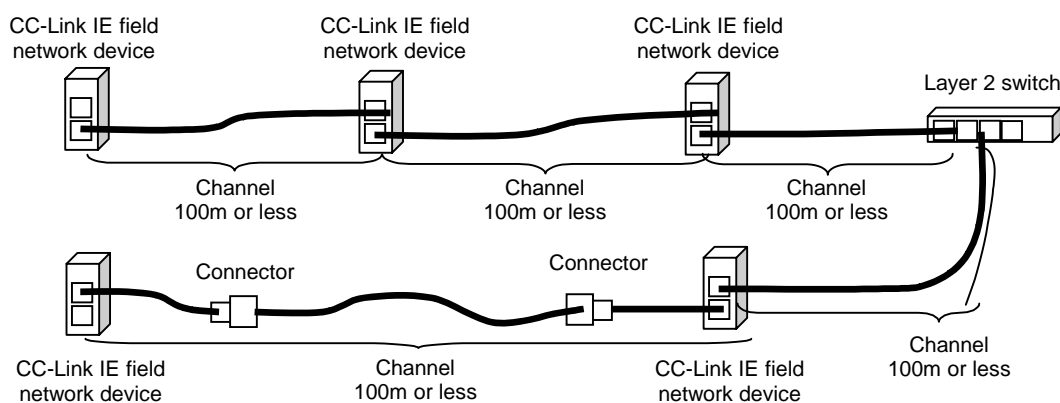

**Fig. 4 Wiring Length**

The wiring between devices, that is, the transmission characteristics of each channel, needs to satisfy specified channel values. It depends on the cable type and ambient temperature, and may not extend up to 100m in certain cases. Specifically, the total amounts of insertion loss and propagation delay of wiring components (cables and connectors) need to be less than or equal to specified channel values. For details, refer to Section 4.4.

In particular, keep in mind the following items.

- When a stranded wire conductor cable is used  
A stranded wire conductor cable generally results in significant insertion loss, resulting in failure to meet the specified channel insertion loss value at a length of 100m.  
\*ANSI/TIA/EIA-568-B Category 5e defines standard channel values presuming a combined 90m single-wire conductor cable and 10m stranded wire conductor cable. A standard 24AWG stranded wire conductor cable has a significantly higher insertion loss of 20% compared to that of a single-wire conductor cable. When wiring is performed using only a stranded wire conductor cable, the cable length is about 85 to 90m based on the standard.  
When wiring across a long distance, use a single-wire conductor cable.
- When the conductor is slender  
When the conductor is slender than 24AWG (0.5mm), insertion loss increases, resulting in a shorter transmittable distance.
- When the cable has a special specification, such as flexible cable  
Prior to use, verify the transmission characteristics (particularly, insertion loss and propagation delay) and transmittable distance presented by the cable manufacturer.
- When multiple cables are connected in combination  
When a device is installed inside a panel and connected with a short cable, the length, insertion loss, and propagation delay of the cable must also be taken in consideration. When a relay connector (jack-jack) or the like is used to connect between multiple cables, the insertion loss and propagation delay of all cables and connectors between the devices must be taken into consideration.
- When the ambient temperature is high  
As the temperature is the higher, the insertion loss of the cable more increases, shortening the transmittable distance. Given an example of a cable with shield, insertion loss increases by about 0.2% per 1°C. The insertion loss specification of the cable is normally set as the value at 20°C. If the temperature of the cable increases, even if only in a part, the cable must satisfy the specified insertion loss at its increased temperature. If there is no margin with respect to the specified channel value at 20°C, the possibility exists that the cable's insertion loss may exceed the specified value when ambient temperature is changed.  
Calculate the insertion loss of the cable at high temperatures based on the temperature coefficient specification published by the cable manufacturer.

## 4.2 Number of Connectors

Make sure that the number of connectors within a single channel is four or less. Note, however, the following conditions:

- The plugs that connect to a device in the each section are not included in the number. A set of plug and jack for cable connection is counted as one connector. Make sure the number of connectors is four or less.

When a relay connector (jack-jack) is used, calculate one relay connector as two connectors.

## 4.3 Connecting Connectors (Plugs/Jacks) and Cables

When connecting a cable and connector (plug/jack), follow the connection method defined in the standard ANSI/TIA/EIA-568 and the connection method and work procedure specified by the connector manufacturer.

The ANSI/TIA/EIA-568 standard specifies two connection method patterns, T568A and T568B, which are indicated below. Any other connection method results in the risk of miswiring, increasing the possibility that predetermined transmission characteristics will not be achieved and communication will fail.

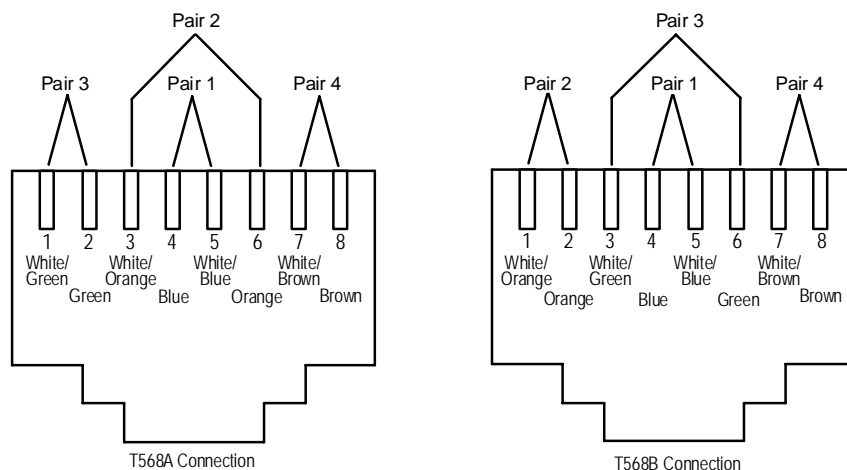

**Fig. 5 Connector Connection Methods**

Unless otherwise specified, we recommend using the same connection method at both ends of the cable.

Additionally, connector connection work – particularly plug area connection work – significantly impacts transmission characteristics. Be careful to follow the work procedure of the connector manufacturer.

For shield treatment as well, Keep in mind to ensure that connector connection is reliably performed.

## 4.4 Transmission Characteristics

The wiring between devices must satisfy the specified channel transmission characteristics of ANSI/TIA/EIA-568-B Category 5e. Note, however, that the possibility exists that the specified channel transmission characteristics may still not be satisfied if the installation technique is inappropriate, even if wiring members (cables/connectors) that satisfy Category 5e are used. Once the wiring is completed, we recommend measuring characteristics using a field tester and verifying whether or not the specified value is satisfied.

The main transmission characteristics specified in the Category 5e standard include the items below. For details on specified values, refer to the ANSI/TIA/EIA-568-B Category 5e standard.

- Insertion loss, IL
- Near end crosstalk, NEXT
- Power sum near end crosstalk, PSNEXT
- Equal level far end crosstalk, ELFEXT
- Power sum equal level far end crosstalk, PSELFEXT
- Return loss, RL
- Propagation delay
- Delay skew

Of the above, insertion loss and propagation delay can be calculated approximately from the specification value of the cable/connector used in the wiring. In particular, when a cable having a length near the 100m (standard upper limit), flexible cable, a special cable with a small conductor size, or when a cable is used in a particularly high ambient temperature environment is used, it is necessary to verify in advance whether or not the cable satisfies the specified channel value within the actual usage state (the actual configuration and at the actual operating ambient temperature).

If the calculated value does not satisfy the specified channel value, (1) satisfy the specified channel length by either shortening the total wiring length by reviewing the layout, (2) shortening the length of the flexible cable or the length of the cable with a small conductor size to the extent possible, or using a cable with a smaller insertion loss and propagation delay. If none of these is possible, investigate to use a layer 2 switch and so on in the network.

All items other than insertion loss and propagation delay require measurement using a measuring device such as a field tester since that cannot be simply calculated from the cable/connector's specifications.

- Approximate calculation of propagation delay

When two types of cables with multiple connectors (plugs and jacks)

Cable 1 propagation delay at 10MHz per 100m: Delay<sub>cable 1</sub> (ns/100m) (Normally 545ns/100m or less)

Cable 2 propagation delay at 10MHz per 100m: Delay<sub>cable 2</sub> (ns/100m)

Total length of cable 1 and cable 2, respectively: L<sub>cable 1</sub>, L<sub>cable 2</sub> (m)

Propagation delay of connector (plug + jack): Delay<sub>conn</sub> (ns) (Normally 2.5ns or less. Calculate as 2.5ns.)

Number of connectors: n

Propagation delay of channel (wiring between devices): Delay<sub>channel</sub> (ns)

$$\text{Delay}_{\text{channel}} = \text{Delay}_{\text{cable 1}} \times L_{\text{cable 1}} / 100 + \text{Delay}_{\text{cable 2}} \times L_{\text{cable 2}} / 100 + \text{Delay}_{\text{conn}} \times n \dots \dots \text{(Formula A)}$$

Verify that the channel delay time calculated above is less than or equal to the specified channel value (555ns).

The following indicates a calculation example in a case where a single-wire conductor cable (cable 1) and a special cable having a long propagation delay (cable 2) are used in combination.

Cable 1 propagation delay at 10MHz per 100m: Delay<sub>cable 1</sub> = 545 (ns/100m)

Cable 2 propagation delay at 10MHz per 100m: Delay<sub>cable 2</sub> = 600 (ns/100m)

Propagation delay of connector (plug + jack): Delay<sub>conn</sub> = 2.5 (ns)

Number of connectors: n = 4

Propagation delay of channel (wiring between devices): Delay<sub>channel</sub> (ns)

$$\text{Delay}_{\text{channel}} = 545 \times L_{\text{cable 1}} / 100 + 600 \times L_{\text{cable 2}} / 100 + 2.5 \times 4$$

Example 1: When the total length of cable 1 is 80m, and the total length of cable 2 is 3m

$$\text{Delay}_{\text{channel}} = 545 \times 80 / 100 + 600 \times 3 / 100 + 10 = 464 \text{ (ns)}$$

The value is less than or equal to the specified channel propagation delay value of 555ns. The cable can be used.

Example 2: When the total length of cable 1 is 40m, and the total length of cable 2 is 60m

$$\text{Delay}_{\text{channel}} = 545 \times 40 / 100 + 600 \times 60 / 100 + 10 = 588 \text{ (ns)}$$

The value is not less than or equal to the specified channel propagation delay value of 555ns. The cable cannot be used.

When a cable with the propagation delay (545ns/100m: specified in the standard ANSI/TIA/EIA-568-B Category 5e ) is used at a total length of 100m and four connectors (propagation delay: 2.5ns) are employed, the Propagation delay becomes 555ns( a value exactly equivalent to the specified channel value). So, the propagation delay value need not be calculated as long as a special cable with a long propagation delay is not employed.

- Approximate calculation of insertion loss

When two types of cables with multiple connectors (plugs and jacks)

Cable 1 insertion loss per 100m:  $IL_{\text{cable 1}}$  (dB/100m)

Cable 2 insertion loss per 100m:  $IL_{\text{cable 2}}$  (dB/100m)

Total length of cable 1 and cable 2, respectively:  $L_{\text{cable 1}}$ ,  $L_{\text{cable 2}}$  (m)

Insertion loss of connector (plug + jack):  $IL_{\text{conn}}$  (dB)

Number of connectors: n

Insertion loss of channel (wiring between devices):  $IL_{\text{channel}}$  (dB)

$$IL_{\text{channel}} = IL_{\text{cable 1}} \times L_{\text{cable 1}}/100 + IL_{\text{cable 2}} \times L_{\text{cable 2}}/100 + IL_{\text{conn}} \times n \dots\dots\dots(\text{Formula B})$$

Temperature conversion formula for cable insertion loss

Cable 1 insertion loss per 100m at 20°C:  $IL_{\text{cable 1}, 20^\circ\text{C}}$  (dB/100m)

Temperature coefficient of cable 1 insertion loss:  $K_{\text{cable 1}}$  (%)

Cable temperature: t (°C)

Cable 1 insertion loss per 100m at t (°C):  $IL_{\text{cable 1}, t^\circ\text{C}}$  (dB/100m)

$$IL_{\text{cable 1}, t^\circ\text{C}} = IL_{\text{cable 1}, 20^\circ\text{C}} \times (1 + (t - 20) \times k/100) \dots\dots\dots(\text{Formula C})$$

Therefore, to calculate the insertion loss of a channel at t°C, using the values of

$IL_{\text{cable 1}, t^\circ\text{C}}$  and  $IL_{\text{cable 2}, t^\circ\text{C}}$  calculated by (Formula C) in place of  $IL_{\text{cable 1}}$  and  $IL_{\text{cable 2}}$  of (Formula B).

Verify that the channel insertion loss calculated above is less than or equal to the specified channel value. While the value must satisfy the specified channel value across the entire bandwidth of 1MHz to 100MHz, normally a general assessment can be made with the insertion loss at 100MHz.

The following indicates a calculation example in a case where a single-wire conductor cable (cable 1) and a stranded wire conductor cable (cable 2) are used in combination with a rise in ambient temperature to 60°C.

Cable 1 insertion loss per 100m at 100MHz and 20°C:  $IL_{\text{cable 1}, 20^\circ\text{C}} = 22.0$  (dB/100m)

Cable 1 insertion loss temperature coefficient:  $K_{\text{cable 1}} = 0.2$  (%)

Cable 2 insertion loss per 100m at 100MHz and 20°C:  $IL_{\text{cable 2}, 20^\circ\text{C}} = 26.4$  (dB/100m)

Cable 2 insertion loss temperature coefficient:  $K_{\text{cable 2}} = 0.2$  (%)

Cable temperature: t = 60 (°C)

Insertion loss of connector (plug + jack) at 100MHz:  $IL_{\text{conn}} = 0.4$  (dB)

Number of connectors: n = 4

Insertion loss of channel (wiring between devices) at 100MHz:  $IL_{\text{channel}}$  (dB)



$$\begin{aligned}
 IL_{\text{channel}} &= (22.0 \times (1+(60-20) \times 0.2/100)) \times L_{\text{cable1}} / 100 + \\
 &(26.4 \times (1+(60-20) \times 0.2/100)) \times L_{\text{cable2}} / 100 + 0.4 \times 4 \\
 &= 23.76 \times L_{\text{cable1}} / 100 + 28.51 \times L_{\text{cable2}} / 100 + 1.6
 \end{aligned}$$

Example 1: When the total length of cable 1 is 80m, and the total length of cable 2 is 3m

$$IL_{\text{channel}} = 23.76 \times 80 / 100 + 28.51 \times 3 / 100 + 1.6 = 21.46 \text{ (dB)}$$

The value is less than or equal to the specified channel insertion loss value at 100MHz of 24dB.

The cable can be used.

Example 2: When the total length of cable 1 is 50m, and the total length of cable 2 is 40m

$$IL_{\text{channel}} = 23.76 \times 50 / 100 + 28.51 \times 40 / 100 + 1.6 = 24.88 \text{ (dB)}$$

The value is not less than or equal to the specified channel insertion loss value at 100MHz of 24dB.

The cable cannot be used.

Note that approximate value is calculated in the above method, and the result may not always match the actual measurement of the channel insertion loss value for various reasons. Be sure to set the cable length so that a margin exists with respect to the insertion loss standard. After wiring, we recommend measuring the value using a measuring device such as a field tester under actual operating conditions to verify that a margin exists.

## Chapter 5 INSTALLATION AND WIRING

### 5.1 Points to keep in mind to set up cable wiring

- **Wiring Route**

For the Wiring route, use ducts or cable racks to the extent possible.

When a conduit line such as a conduit tube is to be used, select a tube diameter taking into consideration dimensions such as connector and boot dimensions. Additionally, when a pull box is to be installed, select a box that satisfies the permissible bending radius of the cable.

Make sure that the wiring route is a dedicated route, to the extent possible.

Also, make sure that the wiring route is not infiltrated with water or oil or the like, and does reach high or low temperatures outside of the compatible ambient temperature range.

- **Minimum bending radius**

Keep Minimum radius of bending cable in using CC-Link IE field network cable.

It may cause decrease of transmission performance and breaking of cable, and so on, when CC-Link IE field network cable is used with less than minimum radius.

Minimum bending radius	When secured	Cable outside diameter x 8 or greater
------------------------	--------------	---------------------------------------

When secured: A minimum radius of bending cable at stable permits the characteristics for long period..

- **Permissible tension**

Do not add tension to cable as much as possible.

If it was pulled strong, it may cause breaking of cable, possibility of not keeping the characteristic and so on.

At connecting: If you have no choice but to tension use within permissible tension.  
(Contact the permissible tension range to the cable manufacturer.)

At Stable: Take notice cable length how to fix not to add tension to the cable.

- **Points to keep in mind against noise**

In order to prevent induced noise keep signal line as far away from power line as possible.

Not set cable up on control panel where high voltage devices are mounted.

Attach surge absorber on devices which radiate noise.

- **Cable lateral pressure**

Do not apply lateral pressure to the cable, such as lateral pressure from cable protective material such as wire protectors, excessive cable insertion into pipes, cable tucking, or excessive band tightening.

It may cause possibility of not satisfying the transmission performance.

- **Stress on connector connection areas**  
Be sure that the weight of the cable itself does not result in stress on connector connection areas. Such stress results in the risk of cable dangling or shifting, unit or connector damage due to unnecessary careless tension, or malfunction from poor connection.
- **Wiring to movable parts**  
When wiring to a movable part, use a flexible cable.  
Additionally, to prevent disconnection in the early stages, note the following items at wiring:
  - Do not scratch or damage the cable sheath.
  - Do not bend, kink, or twist the cable.
  - Minimize the locations where the cable is secured.
  - Do not forcibly secure the cable at a location where the cable moves.
  - Wiring with the optimal length.
  - Maintain a minimum bending radius greater than or equal to 10 times the cable outer diameter.
- **Other**  
Connect the cable after all connected device and communication power supplies is power OFF.

## 5.2 Grounding Method

- Ground (FG grounding) each unit using independent grounding or common grounding.
- Use class D grounding (class 3 grounding). (Grounding resistance: 100Ω or less)

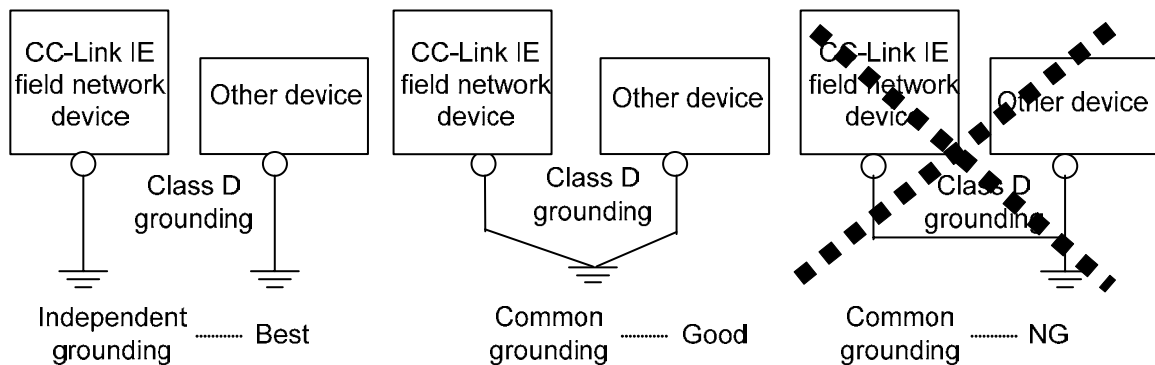

- Use as thick of a ground wire as possible (2mm<sup>2</sup> or larger). Additionally, shorten the distance between the ground point and programmable controller to the extent possible to shorten the ground wire.

## 5.2.1 Supplementary explanation on grounding

### (1) Grounding types

The grounding of CC-Link IE field network compatible products (devices) can be broadly divided into the following types when classified according to purpose:

1. Protective grounding aimed to protect human bodies from electric shock and grounds faults
2. Functional grounding to ensure communication reliability

The grounding of the shield wires of CC-Link IE field network cables is functional grounding to ensure communication reliability.

Protective grounding  
terminal display



Functional grounding  
terminal display



### (2) Supplementations to Grounding method

For protective grounding and functional grounding, either use independent grounding (Figure 6) or common grounding (Figure 7) where cable are wired individually up to the ground point.

In the case of common grounding (Figure 8), noise may enter the functional grounds from the protective ground, making CC-Link IE field network communication instable. Especially, when common grounding is used for the protective grounds and functional grounds (shield wire of CC-Link IE field network cable) of device drives such as inverters and servos, the possibility of instable communication will increase.

- [1] As the ground wire for functional grounding use a copper wire of 1.6mm or more diameter or 2mm<sup>2</sup> or more. [As ground wire up to the ground point, we recommend to use the thickest possible copper wire (14mm<sup>2</sup> or more recommended) at a short distance.]

[2] Do not tie ground wire of the functional grounding together with protective grounding wire or power cable etc. (Noise may enter the ground wire, making communication instable.)

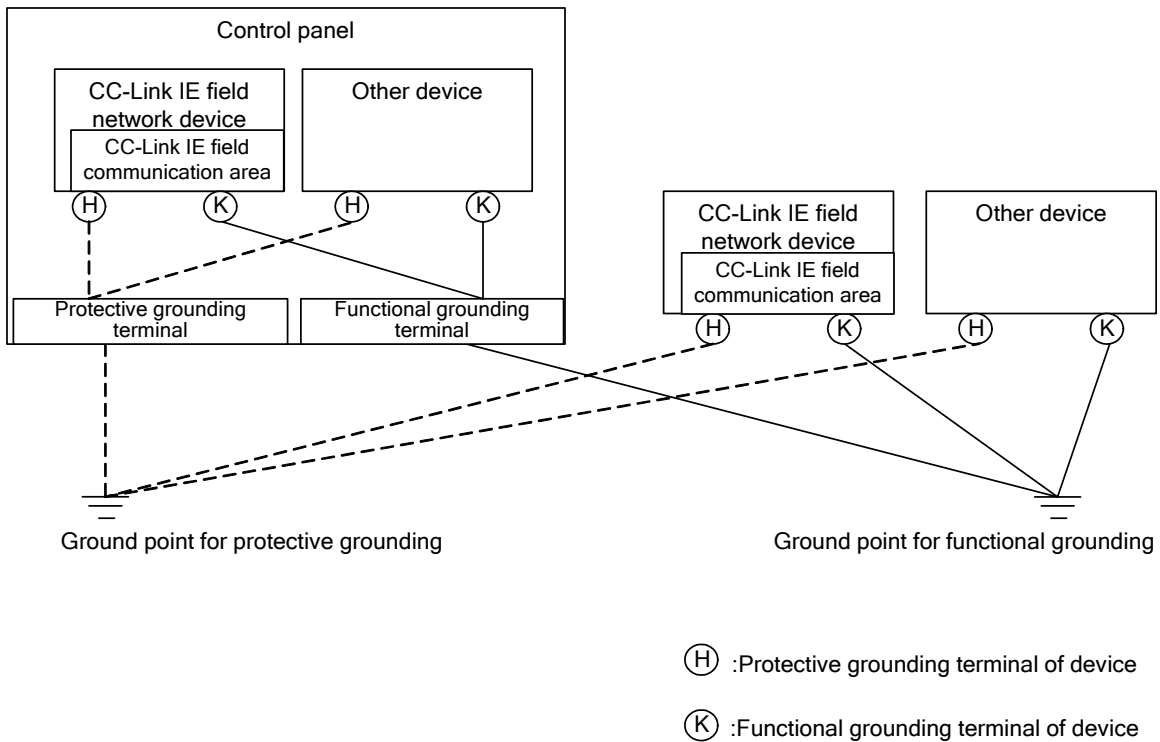

**Fig. 6 Example of Independent Grounding**

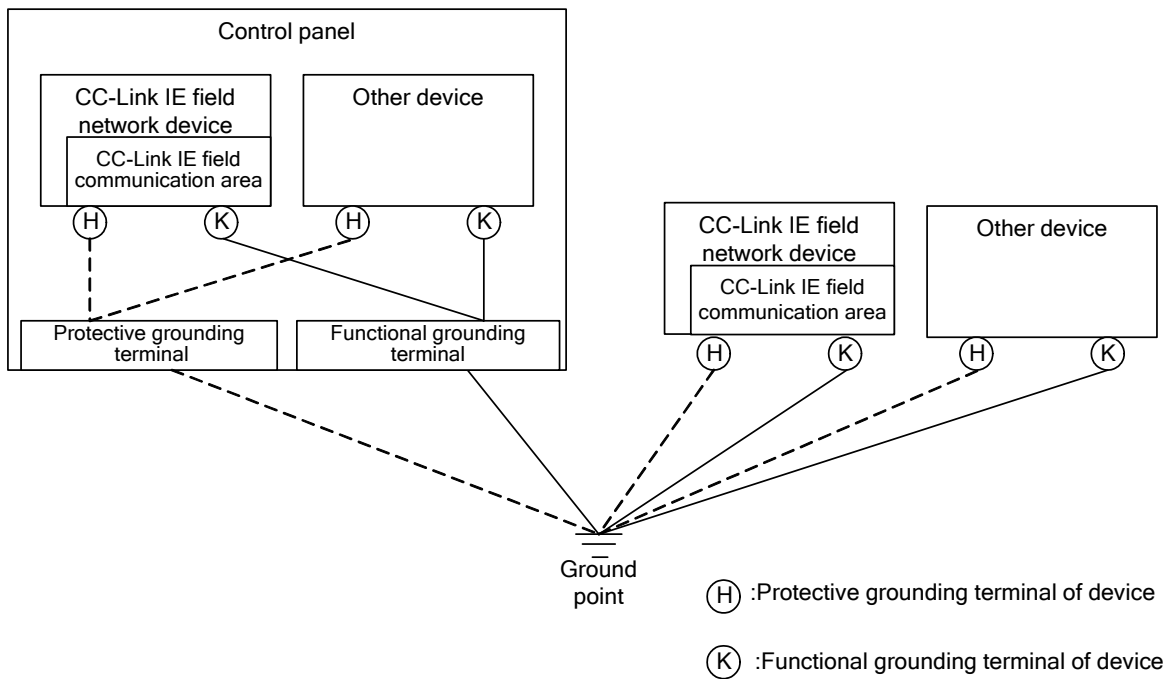

**Fig. 7 Example of Common Grounding**

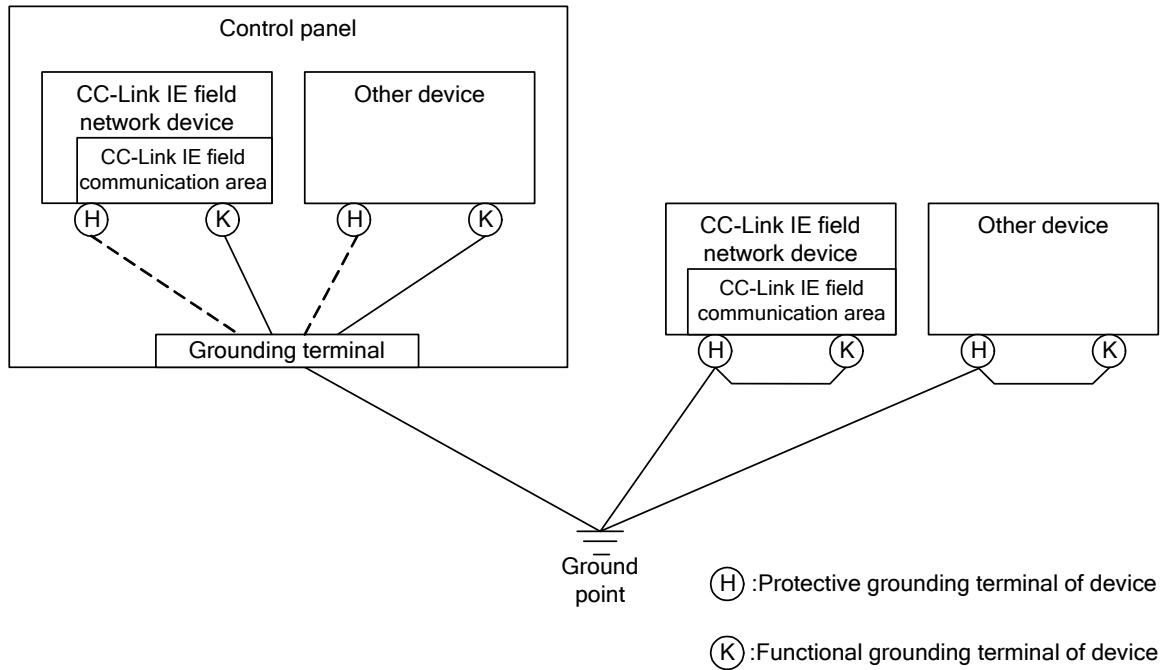

**Fig. 8 Example of Common Grounding**

(3) Wiring example of common grounding

The following shows the wiring example of common grounding.

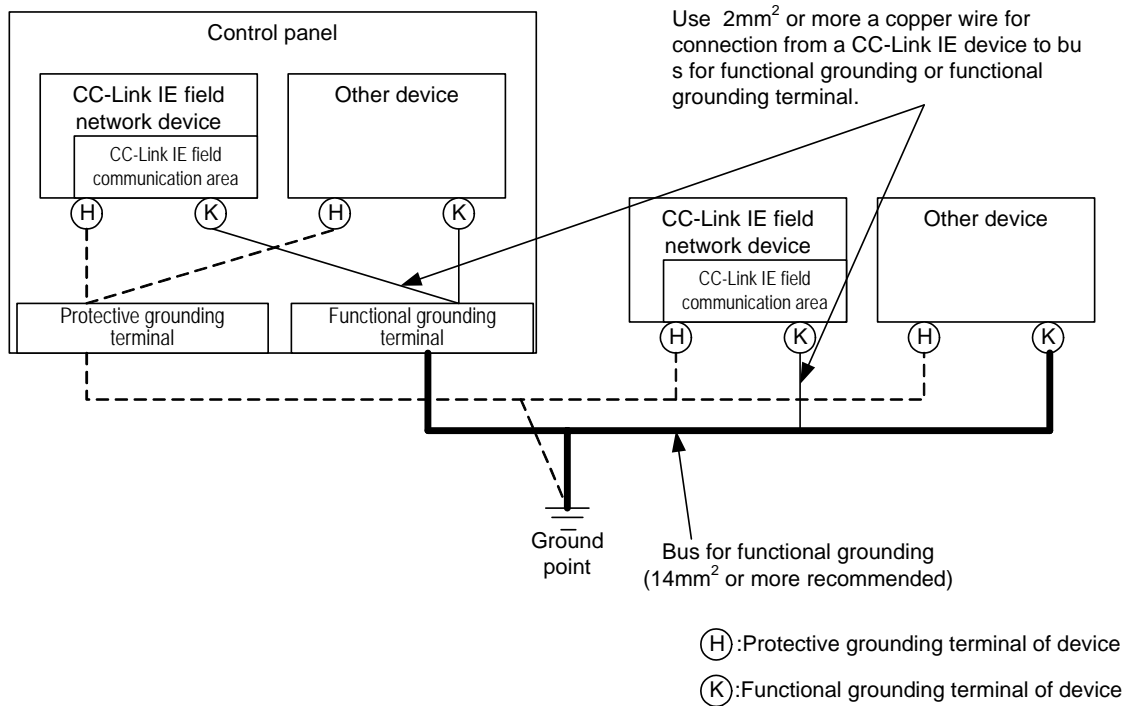

**Fig. 9 Wiring Example of Common Grounding**







Access point:

**CC-Link Partner Association**

6F Meiji Yasuda Seimei Ozone Building, 3-15-58 Ozone, Kita-ku, Nagoya 462-0825 Japan

TEL: 052-919-1588

FAX: 052-916-8655

URL: <http://www.cc-link.org/>

E-Mail: [info@cc-link.org](mailto:info@cc-link.org)

All rights reserved.

